

GP Batteries

Data Sheet

Model No.: GP55AAAH

Type	: Rechargeable Nickel Metal Hydride Cylindrical Cell	
Nominal Dimension (with Sleeve)	: $\Phi = 10.5$ mm H = 43.7 mm	
Applications	: Recommended discharge current 55 to 1650mA	
Nominal Voltage	: 1.2V	
Capacity	: Minimum: 550mAh Typical: 578mAh when discharged at 0.2C to 1.0V at 20°C	
Charging Condition	: 55mA for 16 hrs at 20°C	
Fast Charge	: 275mA to 550mA (0.5 to 1C) charge termination control recommended control parameters: - ΔV : 0 - 5mV DT/dt** : 0.8°C/min (0.5 to 0.9C) : 0.8 - 1°C/min (1C) TCO** : 45 - 50°C Timer** : 105% nominal input ** for reference only	
Service Life	: >500 cycles (IEC standard)	
Continuous Overcharge	: 55mA maximum current for 1 year No conspicuous deformation and/or leakage	
Weight	: 13.0 g	
Internal Resistance	: Average 40m Ω upon fully charged (Range 30-50m Ω) at 1000Hz	
Max. Charging Voltage	: 1.5V at 55mA charging	
Ambient Temperature Range	Standard Charging	: 0 to 45°C
	Fast Charging	: 10 to 45°C
	Discharging	: -20 to 50°C
	Storage	: -20 to 35°C

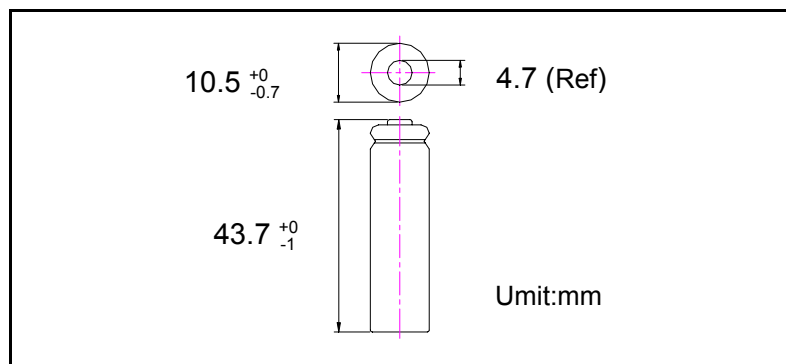

Fast Charge (Charge control required)

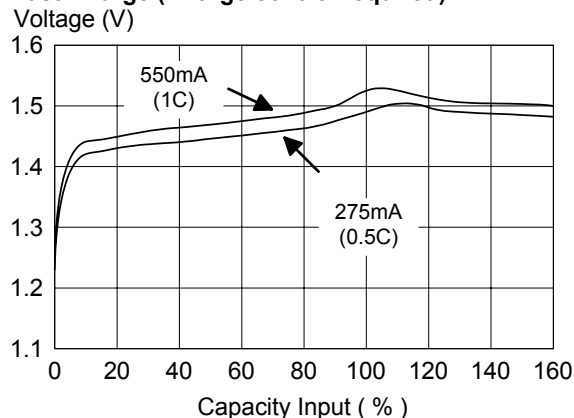

Low Rate Discharge

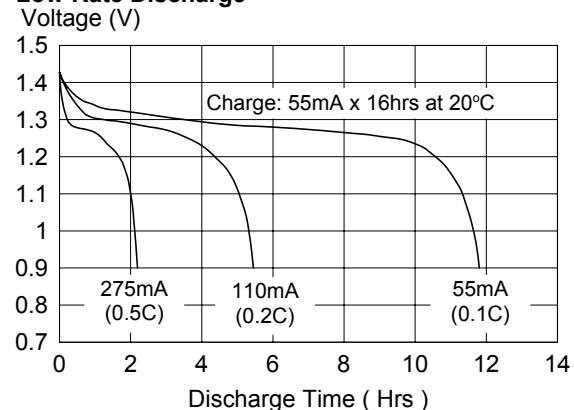

High Rate Discharge

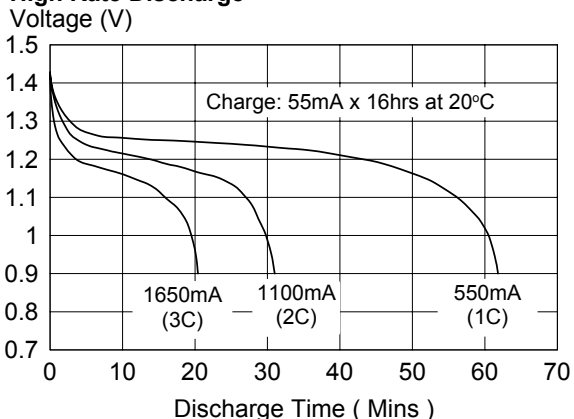

* The information (subject to change without prior notice) contained in this document is for reference only and should not be used as a basis for product guarantee or warranty. For applications other than those described here, please consult your nearest GP Sales and Marketing Office or Distributors.